

FIG. NO.	CATALOG NUMBER	CONDUCTOR RANGE (MIN - MAX)	CU	CU WELD	DIM A	DIM B	DIM C	DIM D	DIM E	DIM F	STANDARD PACK
3	GD110	.12 - .13 [3.1 - 3.3]	8 SOL	-	-	-	-	-	9.25 [235]	6.88 [175]	100
3	GD111	.16 - .17 [4.0 - 4.4]	6 SOL	-	6.69 [170]	3.75 [96]	6.38 [162]	4.25 [108]	9.25 [235]	6.88 [175]	50
3	GD112	.19 - .20 [4.9 - 5.2]	4 SOL	8A STR	6.88 [175]	3.75 [96]	6.50 [165]	4.19 [107]	9.25 [235]	6.88 [175]	50
3	GD113	.22 - .23 [5.7 - 5.9]	3 SOL, 4 STR	6A STR	6.88 [175]	3.75 [96]	6.75 [172]	4.50 [115]	9.50 [241]	6.88 [175]	25
3	GD114	.25 - .26 [6.3 - 6.6]	2 SOL, 3 STR	5A STR	8.62 [219]	4.88 [124]	8.00 [203]	5.00 [127]	10.50 [267]	7.13 [181]	25
3	GD115	.28 - .29 [7.2 - 7.4]	1 SOL, 2 STR	4A STR	8.88 [226]	5.00 [127]	7.81 [199]	4.81 [122]	10.50 [267]	7.13 [181]	25
3	GD116	.32 - .33 [8.1 - 8.3]	1/0 SOL, 1 STR	3A STR	9.00 [229]	5.00 [127]	7.81 [199]	4.81 [122]	10.50 [267]	7.13 [181]	25
3	GD117	.36 - .37 [9.1 - 9.3]	2/0 SOL, 1/0 STR	2A STR	9.50 [242]	5.00 [127]	11.88 [302]	8.25 [210]	13.00 [330]	9.25 [235]	25
3	GD118	.40 - .41 [10.2 - 10.5]	3/0 SOL, 2/0 STR	-	9.44 [240]	4.88 [124]	12.00 [305]	8.50 [216]	13.00 [330]	9.25 [235]	25
3	GD119	.45 - .46 [11.5 - 11.8]	4/0 SOL, 3/0 STR	-	10.88 [277]	5.50 [140]	12.25 [311]	8.13 [207]	13.75 [350]	8.13 [207]	25
3	GD120	.52 - .53 [13.2 - 13.4]	4/0 STR	-	11.00 [280]	5.62 [143]	12.63 [321]	8.38 [213]	13.50 [343]	8.75 [223]	25
3	GD121	.57 - .58 [14.4 - 14.7]	250 KCMIL STR	-	11.13 [283]	5.62 [143]	12.75 [324]	8.50 [216]	-	-	25
1	GD523	.62 - .63 [15.8 - 16.1]	300 KCMIL STR	-	13.81 [351]	7.19 [183]	-	-	-	-	10

ITEM	DESCRIPTION	MATERIAL
1	SHELL	COPPER
2	CONE	COPPER
3	SPRING	GALV. STEEL
4	BAIL	GALV. STEEL OR STAINLESS STEEL
5	RETAINING WASHER	STEEL
6	COTTER PIN	STAINLESS STEEL
7	CLEVIS PIN	GALV. STEEL

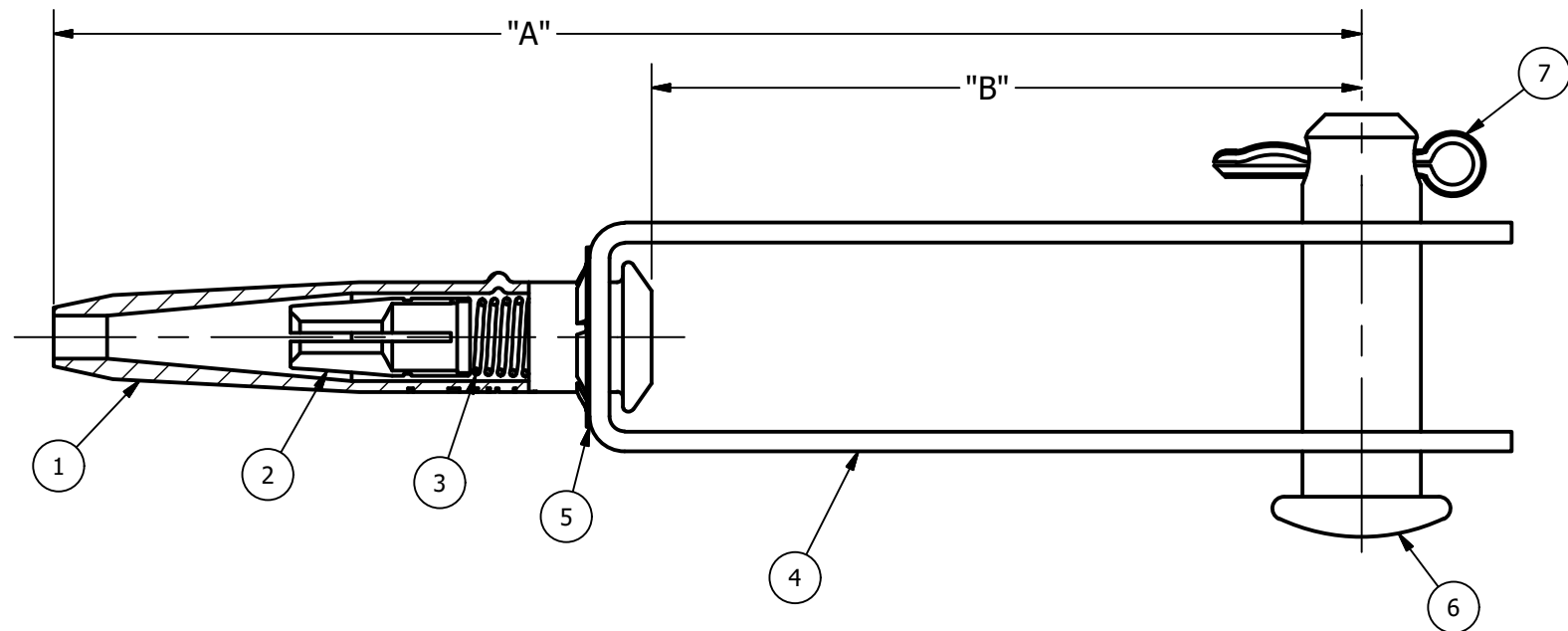

FIG 1
CLEVIS BAIL

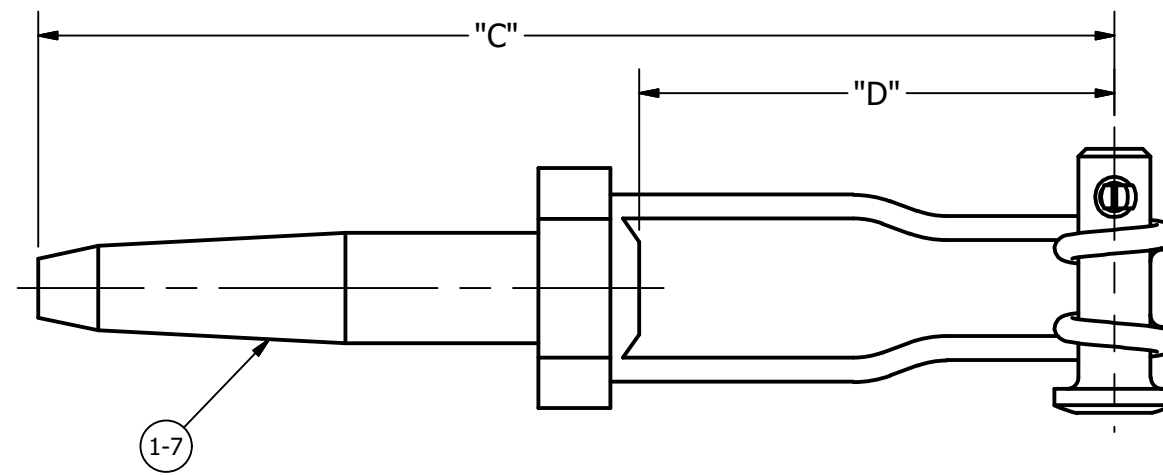

FIG 2
Z BAIL

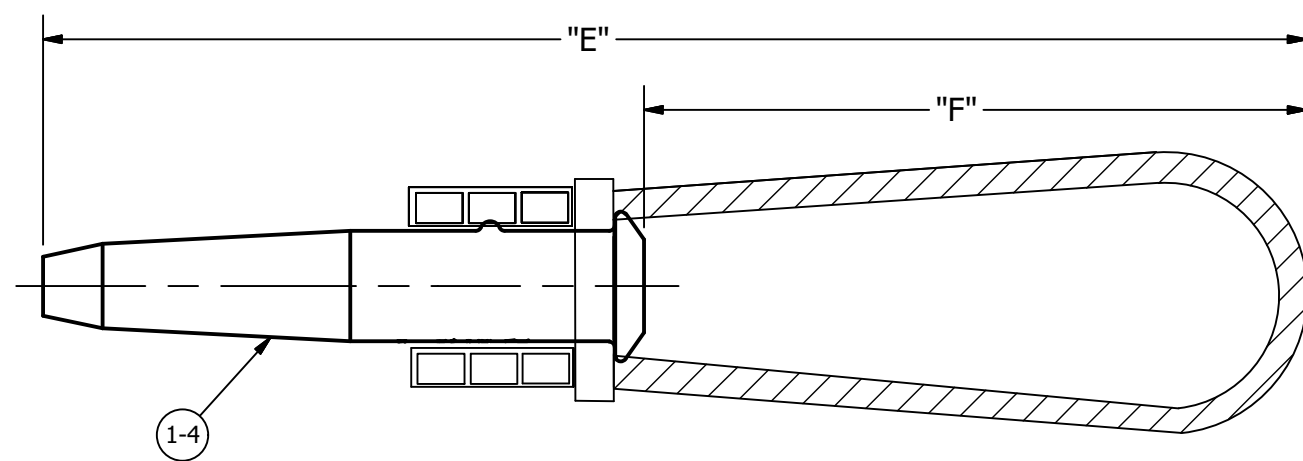

FIG 3
FLEX BAIL

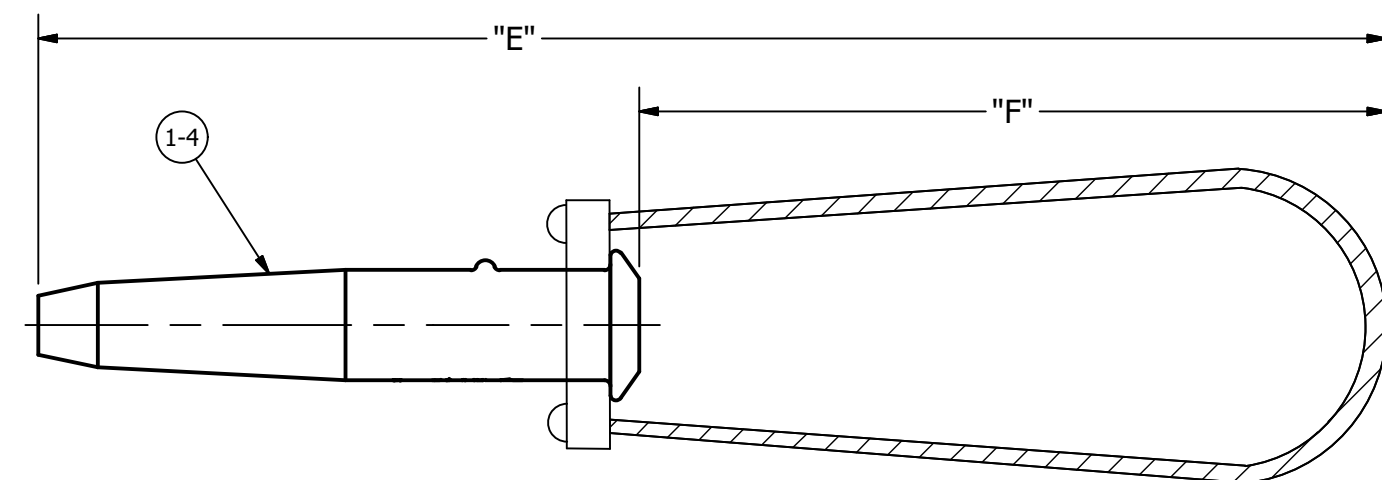

FIG 4
SEMI-FLEX BAIL

NOTES:

- ALL DIMENSIONS FOR REFERENCE ONLY. DISTANCE IN. [MM], FORCE LBS. [kN], TORQUE IN. LBS. [N.m], & WEIGHT LBS. [KG].
- RATINGS:
 - CONSULT FACTORY FOR RATING.
- CERTIFICATIONS, SPECIFICATIONS, & STANDARDS:
 - ANSI C119.4
- A SUFFIX IS ADDED TO THE CATALOG NUMBER TO DESIGNATE THE REQUIRED FITTINGS AS SHOWN IN THE TABULATION (EXAMPLE: GD111Z):
 - "R" - SEMI-FLEX BAIL (FIGURE 4)
 - "Z" - Z BAIL (FIGURE 2)
 - "GC5XX" - REPLACE THE FIRST 1 IN THE CATALOG NUMBER WITH A 5 FOR A CLEVIS BAIL (FIGURE 1)

76930	1/4/2019	NLA	SD
EC #	DATE	CHG BY	RESP ENG
DESC OF DWG: UPDATED TABLE			
REASON (S) FOR CHANGE: DISPOSITION OF MAT'L:			

HPS

CONFIDENTIAL: THIS DRAWING AND ITS CONTENTS ARE CONFIDENTIAL AND THE EXCLUSIVE PROPERTY OF HUBBELL POWER SYSTEMS. NO PUBLICATION, DISTRIBUTION OR COPIES MAY BE MADE WITHOUT THE WRITTEN CONSENT OF HUBBELL POWER SYSTEMS. HUBBELL POWER SYSTEMS UNPUBLISHED ALL RIGHTS RESERVED UNDER THE COPYRIGHT LAWS

GD5XX/GD1XX SERIES AUTOMATIC CU DEADENDS			
SIZE	DWG NO.	CAT / PART / ASSY NO.	REV
C	CC-24780	SEE TABLE	02
DO NOT SCALE THIS DRAWING	DRN BY	SD	DATE 06/29/17 SHEET 1 OF 1